



Air Amplifier

MPLV2, SPLV2, GPLV2

Installation and operating manual

Key information!
Follow the manual for safe and proper use.
Keep the manual near the machine for later reference.

MAXIMATOR GmbH
Lange Straße 6
99734 Nordhausen
Germany
Phone: +49 3631 9533-0
e-mail: info@maximator.de
Internet: www.maximator.de

Warranty and liability:

As a general rule, the “General Terms and Conditions” of Maximator GmbH shall apply. These terms and conditions are available at <http://www.maximator.de>.

Warranty and liability claims shall not be accepted if they can be attributed to one or more of the causes mentioned in this manual or explicitly stipulated below:

- Any use other than the intended use indicated in this manual
- Improper commissioning, operation or maintenance
- Operation with faulty safety equipment or incorrectly installed safety equipment and safeguards
- Failure to observe the commissioning, operation and maintenance instructions in this manual
- Insufficient monitoring of wear parts
- Wear on seals, guiding elements, etc. due to ageing and operation

25/05/2023 Translation

© Copyright 2023 Maximator GmbH - All rights reserved

Contents

1	General information	5
1.1	Information regarding this manual	5
1.2	Order code	5
1.3	Rating plate.	6
1.4	Explanation of symbols	7
1.5	List of abbreviations and formula signs used	8
1.6	Qualification of the personnel	8
2	Safety and protection measures	9
2.1	Personal protective equipment.	9
2.2	Signs and labels.	9
2.3	Work and danger zone.	9
2.4	Non obvious hazards	10
2.5	Residual risks.	11
2.5.1	Start-up and shut down	11
2.5.2	Unexpected restart	11
2.5.3	Risk of injury posed by noise	11
2.5.4	Risk of injury posed by raised particles or ice crystals.	11
2.5.5	Hazardous operating fluids.	11
3	Product description.	12
3.1	Design and function.	12
3.2	Intended use	13
3.3	Foreseeable misuse	13
3.4	Misuse	13
3.5	Ports.	13
3.6	Technical specifications	14
3.6.1	Operating conditions	14
3.6.2	Dimensions and weight	16
3.6.3	Performance values	16
3.6.4	Service life	17
4	Transport, packaging and storage	18
4.1	Dimensions and weight	18
4.2	Delivery	18
4.3	Packaging	18
4.4	Storage.	18

Contents

5	Installation	19
5.1	Prerequisites for installation	19
5.2	Air amplifier installation	19
5.3	Installation of connecting lines.	20
5.3.1	Connecting the drive air	20
5.3.2	Control air connection.	20
5.3.3	Connecting the inlet line and outlet line.	20
5.3.4	Exhaust silencer installation.	20
5.4	Commissioning	20
5.4.1	Prerequisites for commissioning	20
5.4.2	Commissioning	20
6	Operation	22
6.1	Prerequisites for operation	22
6.2	Normal, safe operation	22
6.3	Abnormal situations during operation	22
6.4	Signs indicating the product is no longer safe to use	22
6.5	Put the air amplifier in a safe state	22
7	Maintenance	23
7.1	Maintenance intervals.	23
7.2	Maintenance work	24
7.2.1	System inspection	25
7.2.2	Leak-testing the connections	26
7.2.3	Inspect screws and connecting lines.	26
7.2.4	Clean air amplifier.	27
7.2.5	Check fastening elements and connecting elements	27
7.2.6	Leak detection	28
7.2.7	Repair air amplifier	29
7.3	Spare parts and consumables	30
7.4	Accessories and special tools	30
7.5	Customer service	30
8	Troubleshooting	31
8.1	Drive side	31
8.2	High pressure side.	32
9	Removal and disposal	33
9.1	Prerequisites for removal and disposal	33

9.2	Removal	33
9.3	Disposal	33
10	Use in explosion-prone zones	34
10.1	General information	34
10.2	Temperature class	35
10.3	Operation and maintenance.	36
11	Summary of ignition hazards.	37
	Appendix	38

1 General information

1.1 Information regarding this manual

The pneumatically driven air amplifier from MAXIMATOR is a self-reversing, oscillating pressure intensifier and is used to deliver and compress air and nitrogen without the use of oil. The drive fluid and compressed fluid are fed from the same supply line and are therefore identical in terms of pressure and fluid.

These instructions apply to air amplifier models MPLV2/SPLV2/GPLV2 (in the sections below referred to as “compressor”) and with a serial number of above 23000001.

The provided general drawing is an integral part of these instructions and thus must be stored together.

1.2 Order code

The order code for the compressor is structured as follows:

$$\frac{\text{XPLV2}}{\text{a}} - \frac{\text{X}}{\text{b}}$$

a **Model**

for example: MPLV 2

b **additional codes for device options and/or variants**

for example: -NPT, -FEC

1.3 Rating plate

The rating plate is located on the pneumatic cylinder of the compressor and contains the following information:¹:

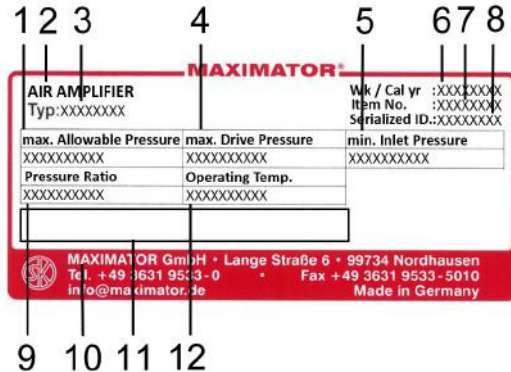

- | | | | |
|---|---|----|---------------------------------------|
| 1 | Max. permitted operating pressure | 8 | Serial number |
| 2 | Air amplifier | 9 | Gear ratio |
| 3 | Type (specifications from the order code) | 10 | Manufacturer contact information |
| 4 | Maximum drive pressure | 11 | Label according to applied guidelines |
| 5 | Minimum inlet pressure | 12 | Operating temperature range |
| 6 | Calendar week/year of manufacture | | |
| 7 | Article number | | |

¹ Individual compressors may have different rating plates, e.g. metal ones

1.4 Explanation of symbols



DANGER

This combination of symbol and signal word indicates a hazardous situation which - if not avoided - may lead to severe injuries or death.



WARNING

This combination of symbol and signal word indicates a potentially hazardous situation which - if not avoided - may lead to severe injuries or death.



CAUTION

This combination of symbol and signal word indicates a potentially hazardous situation which - if not avoided - may lead to light or minor injuries.

NOTICE

This combination of symbol and signal word indicates a potentially hazardous situation which - if not avoided - may lead to property damage or damage to the environment.



WARNING

This combination of symbol and signal word characterises contents and instructions for the intended use in potentially explosive areas. If failing to comply with instructions marked as such, an increased risk of explosion will be posed and may result in severe or fatal injuries.

1.5 List of abbreviations and formula signs used

Abbreviation	Description
A	Gas inlet
Fig.	Figure
ATEX	EU explosion prevention directive
B	Gas outlet
E	Exhaust port
CET	Central European Time
P _L	Drive air inlet
PPE	Personal protective equipment
Tab.	Table
V1	Spool valve air supply
X	Control air port
Y	Pilot valve air supply

Tab. 1-1 List of abbreviations

Formula symbol	Description
p _B	Operating pressure
p _L	Drive pressure
i	Gear ratio
n _{sp}	Strokes under standstill pressure
V _{leak}	Leakage volume
V _{stroke}	Stroke volume

Tab. 1-2 Formula symbol

1.6 Qualification of the personnel

Only qualified personnel who are specialised and have been trained to do so must work on the air amplifier. Allowing unqualified personnel to work on the compressor or enter the danger zone creates hazards which could lead to death, severe injuries and significant property damage.

2 Safety and protection measures

The following sections stipulate the residual risks associated with the product, even when used as intended. In order to reduce the risk of personal injuries and material damage, and to prevent hazardous situations, you must observe the safety information listed in this section and the warnings in all other sections of this manual.

2.1 Personal protective equipment

Personal protective equipment (in other sections also referred to as PPE) protects personnel from occupational safety and health hazards while at work.

Wearing personal protective equipment may be required during work on the product. Wherever possible, this personal protective equipment is listed in these instructions for the individual work steps.

However, detailed specifications of the required protective equipment can only be determined with full knowledge of the system. The required personal protective equipment should therefore be determined by the user.

2.2 Signs and labels

The following signs are found on the product.

Over time, labels can become unrecognisable due to dirt or other causes. As a result, hazards cannot be identified, or necessary operating indications cannot be followed. Resulting errors can lead to severe injuries or death.

Keep the labels in good, legible condition and replace any damaged labels.

Signs and labels	Graphic display
<p>Rating plate:</p> <p>The rating plate is affixed to the pneumatic cylinder of the air amplifier. The rating plate indicates the operating characteristics of the air amplifier.</p>	 <p>The graphic shows a red-bordered label for a MAXIMATOR AIR AMPLIFIER. It contains technical specifications such as max. Allowable Pressure, max. Drive Pressure, min. Inlet Pressure, Pressure Ratio, and Operating Temp. It also features certification marks for EAC, CE, and Ex, and contact information for MAXIMATOR GmbH in Nordhausen, Germany.</p>

Tab. 2-1 Overview of labels

2.3 Work and danger zone

The danger zone comprises the entire area surrounding the product. The hazards associated with the product and the danger zone depend on the application and the installation location. The danger zone should therefore be determined by the user.

During assessment, check the following leak points:

leak point	leak type	leak source	Comment
silencer	normal operating leakage	air cylinder	permanent leak of operating fluids
air cylinders/caps	unexpected	defective air cylinders, caps or seals on these components	
screw fittings	unexpected	loose screw fitting, faulty screw fitting	
drive connection lines	unexpected	connection line, fitting, O-ring	

Tab. 2-2 leak point danger zone

The hazards are primarily due to the high pressure and extreme temperatures of the operating fluid and/or the hazardous substances used.

The system designer must determine detailed danger zones as part of his job and can use his special knowledge of high-pressure technology and the hazardous substances used in each case.

2.4

Non obvious hazards

Using asphyxiant operating fluids can lead to severe injuries or death by asphyxiation. Assess the risk for the equipment in the risk assessment. The following are some potential corrective actions:

- Operate the compressor in an adequately ventilated space.
- Check the compressor for leaks on a regular basis.
- Ensure that lines are connected in such a way as to remain leak-tight for a long time.
- If necessary, use connecting lines to remove the escaping operating fluids.

Assess the risk for the equipment in the risk assessment.

2.5 Residual risks

2.5.1 Start-up and shut down

There is no command device for safe shut-down (E-stop). This can lead to severe injuries or death.

Assess the risk for the equipment in the risk assessment.

2.5.2 Unexpected restart

When restoring the pneumatic energy supply or in case of changes made to the operating parameters, the compressor may start accidentally. This can lead to severe injuries or death.

Assess the risk for the equipment in the risk assessment.

2.5.3 Risk of injury posed by noise

The noise level emitted in the work area depends on the mounting and application.

Assess the risk for the equipment in the risk assessment.

2.5.4 Risk of injury posed by raised particles or ice crystals.

Escaping gas raises particles or ice crystals and can cause injuries to the eyes.

Assess the risk for the equipment in the risk assessment.

2.5.5 Hazardous operating fluids

Improper use of operating fluids can lead to serious accidents resulting in death.

Assess the risk for the equipment in the risk assessment.

Active leaks can lead to serious accidents resulting in death.

Assess the risk for the equipment in the risk assessment.

3 Product description

3.1 Design and function

Structure (MPLV 2/SPLV 2/GPLV 2)

schematic diagram xPLV2 without control air

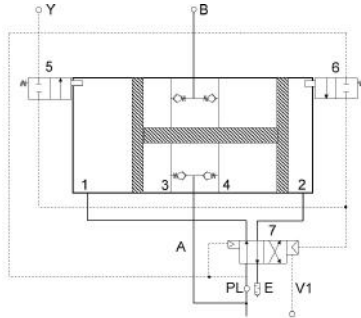

schematic diagram xPLV2 with control air

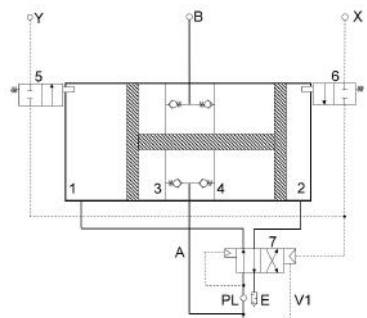

Tab. 3-1 schematic diagram

1	drive chamber 1	A	Gas inlet to the air amplifier
2	drive chamber 2	B	Gas outlet from the air amplifier
3	compression chamber 1	P_L	Drive air inlet
4	compression chamber 2	E	Exhaust port/silencer
5	Pilot valve lower cap	V1	Air supply to spool valve
6	Pilot valve top cap	Y	Pilot valve air supply
7	Spool valve	X	Pilot supply port (SPLV2/GPLV2)

Functional description

The operating principle of an air amplifier is similar to that of a pressure intensifier. As shown in the schematic diagram, drive air inlet P_L and gas inlet A on the air amplifier are supplied by the same supply line.

So the supply line pressure is always applied to two identically-oriented and identically-sized piston surfaces, which are only opposed by a single pressurised piston surface. The pistons of the air amplifier perform reciprocating movements until the stall pressure is reached. The pistons deliver and compress the operating fluid by means of the check valves in gas inlet A and gas outlet B. The output pressure results from the set pressure in the supply line, which is applied to ports P_L and A and the fixed pressure ratio.

Product description

The continuous operation is achieved by means of an internally controlled directional valve, the spool valve (7). The spool valve alternately guides the operating fluid from the supply line into the two drive chambers (1 and 2). The spool valve is controlled by two directional valves, the pilot valves (5 and 6), which are operated mechanically by the pistons at their end positions. The pilot valves vent the operating area of the control slide valve.

Once the stall pressure is reached, the forces in all four operating chambers are balanced. The air amplifier stops and no longer consumes drive fluid. If the pressure drops on the high pressure side or increases on the supply side, the air amplifier automatically restarts, while the operating fluid is compressed until an equilibrium of forces is restored.

In air amplifiers equipped with a pilot air port X, the operating area of the spool valve will only be supplied with air if air pressure is present on the pilot port. If no pilot air pressure is present, the amplifier will not cycle.

3.2 Intended use

Within their technical limits, air amplifiers are used to deliver and compress compressed air and nitrogen. The drive unit and high pressure unit are supplied by the same supply line, thus receiving the same fluid at the same pressure. Other fluids and other connections, in order to use different pressures on the drive side and the high-pressure side, must be approved individually by Maximator.

If the air amplifier bears an ATEX label and comes with a declaration of conformity, it is designated for use in corresponding potentially explosive areas.

3.3 Foreseeable misuse

The product may only be used in accordance with the indications in this manual.

The product cannot be used for:

- sealing containers

3.4 Misuse

Unauthorised modifications or technical changes to the product may lead to accidents with serious or fatal injuries.

Never carry out unauthorised modifications or technical changes to the product!

3.5 Ports

Comply with the connected load specifications for all interface connections. Refer to the enclosed general drawing for the connection ports available on the air amplifier.

The following interfaces are standard on the air amplifier:

Drive air inlet "P_L"

Input of drive fluid.

Gas inlet "A"

Input of operating fluid.

Gas outlet "B"

Output of operating fluid.

Exhaust port "E"

Output of expanding drive fluid.

Control air connection "X" (SPLV2 and GPLV2 only)

Port for control air. The compressor will only operate if the control air connection is pressurised. The pressure of the control air must always be larger or equal to the drive pressure to ensure flawless function. The control air is subject to the same fluid quality requirements as the drive fluid/operating fluid.

Spool valve air supply port "V1"

Spool valve air supply and ventilation. The port must not be obstructed.

Pilot valve "Y" exhaust port

Bleeding of the spool valve actuator chamber. An air pulse escapes here after each stroke. The port must not be obstructed.

This port can be used to connect a stroke counter.

3.6 Technical specifications

3.6.1 Operating conditions

Ambiance

Specification	Value	Unit
Ambient temperature, min.	- 20	°C
Ambient temperature, max.	+ 60	°C
Installation area	protected against climatic exposure	

Tab. 3-2 Ambient conditions

Product description

Drive or operating fluids (based on ISO 8573-1)

Specification	Value	Unit
Drive pressure p_L^a , min.	1	bar
Drive pressure p_L^b , max.	10	bar
Operating fluid	Compressed air or nitrogen	
Operating fluid temperature, min. ^c	-20	°C
Operating fluid temperature, max. ^d	+60	°C
Max. compressed air purity class of oil (Class 4)	5	mg/m ³
Max. particle count at 0.1 - 0.5 µm size (Class 3)	information not available	units
Max. particle count at 0.5 - 1.0 µm size (Class 3)	90000	units
Max. particle count at 1.0 - 5.0 µm size (Class 3)	1000	units
Max. solids, particle concentration (Class 6)	5	mg/m ³
Max. pressure dew point for humidity (Class 4)	+3 ^e	°C
Particle size, max.	10	µm

a. Drive pressure p_L designates the pressure at which gas inlet A and drive air inlet P_L are supplied.

b. Drive pressure p_L designates the pressure at which gas inlet A and drive air inlet P_L are supplied.

c. Depending on the design of the air amplifier. See enclosed general drawing.

d. Depending on the design of the air amplifier. See enclosed general drawing.

e. For fluid temperature of 20 °C; depending on the temperature of the operating fluid, different values may be required.

Tab. 3-3 Requirements for drive and operating fluids

In case of applications with special specifications for the quality of the fluid that go beyond what is usual in high-pressure system designs, the system manufacturer will have to determine whether the compressor is adequate for the application. For example, these applications may include (but are not limited to) the following:

- Compression of breathing air
- Handling of diving gases
- Compression of auxiliary fluids in food production
- Applications within the pharmaceutical industry without direct contact

Operation with compressed air

Maximator air amplifiers generally do not need a compressed air oiler as they are treated with lubricant during installation. However, after the first time an oiler is used, the drive fluid should always be oiled, since the oil washes the lubricant out. In case a compressed air oiler is used, the oil must comply with DIN 51524 - ISO VG 32 specifications.

If dry or very dry compressed air is used, a gas booster with FEC option is recommended.

Operation with nitrogen

As standard, all Maximator air amplifiers can be operated with nitrogen. This is equivalent to operation with dry or very dry compressed air.

3.6.2 Dimensions and weight

The dimensions and weight of the product are indicated in the general drawing.

3.6.3 Performance values

The performance values of the air amplifier can be found on the rating plate and general drawing.

For more detailed information on the air amplifier, including characteristic curve, please refer to the corresponding data sheet on the Maximator website at <http://www.maximator.de>.

Permissible leakage MPLV 2/SPLV 2/GPLV 2

With the air amplifier types listed above, assessing leakage at the HP seal and the check valves is a complicated process. Refer to the "Maintenance" section for instructions on measuring leakage and detecting wear.

The following limit values apply to the air amplifiers in as-delivered condition:

Criterion	Limit value	Unit
Amplifier Strokes when at stall pressure n_{sp}	1	1/min.

Tab. 3-4 Permissible limit values in as-delivered condition MPLV 2/SPLV 2/GPLV 2

The following limit values must be observed to ensure operational safety. The applicable limit values could be lower, depending on the equipment:

Criterion	Limit value	Unit
Amplifier strokes when at stall pressure n_{sp}	2	1/min.

Tab. 3-5 Permissible limit values for operational safety MPLV 2/SPLV 2/GPLV 2

Product description

Given the following conditions, based on the calculated strokes at stall pressure n_{sp} , it is possible to obtain a rough estimate of the leakage volume:¹

- The strokes n_{sp} calculated at stall pressure and with gas outlet (B) shut off result from the leakage from the high pressure seal only.
- Leakage at stall pressure and leakage in the operating point of the air amplifier are comparable.

The leakage volume can be estimated as follows:

$$V_{leak} = V_{stroke} * \rho_B * n_{sp}$$

3.6.4 Service life

The service life of the product depends on the conditions of use. The service life should therefore be determined and defined by the user.

¹ The actual leakage volume in the operating point depends on additional factors and can in fact deviate significantly from the calculated value.

4 Transport, packaging and storage

4.1 Dimensions and weight

The dimensions and weight of the product are indicated in the general drawing.

4.2 Delivery

Scope of delivery

Designation	Quantity
Air amplifier	1
Installation and operating manual including Declaration of Incorporation and EU Declaration of Conformity	1
General drawing	1

Tab. 4-1 Scope of delivery

4.3 Packaging

The individual packages are packed according to the conditions expected for transport. Separate packaging should be used for transport and dust protection. The packaging is supposed to protect the individual components against transport damage, corrosion and other damage up to its place of use.

Do not remove the dust protection until shortly before installation.
Dispose of the packaging materials in an environmentally friendly manner.

4.4 Storage

Note the following with regard to package storage:

- Do not store the packages out of doors.
- Keep the packages dry and dust-free.
- Do not expose the packages to corrosive fluids.
- Keep the packages protected from sunlight.
- Prevent mechanical vibrations.
- Maintain a storage temperature of -20°C to +60°C.
- The relative humidity should not exceed 60%.

Storage instructions in addition to the specifications mentioned here may be attached to the packages.

5 Installation

5.1 Prerequisites for installation

Observe the manual and general drawing of the product. In addition, the following conditions must be met:

- The product must be free of damage.
- The product must be easily accessible from all sides.
- Do not expose the product to any external heat or radiation sources.
- Install the product in a clean environment.

5.2 Air amplifier installation

The product is enclosed in dust-protection packaging. Do not remove this packaging until shortly before installation. Dispose of this packaging in an environmentally friendly manner.

Attach the air amplifier to the fastening holes provided using screws or bolts with a strength of at least 4.6. Determine the adequate screw or bolt size using the enclosed general drawing.

The preferred installation position is vertical.

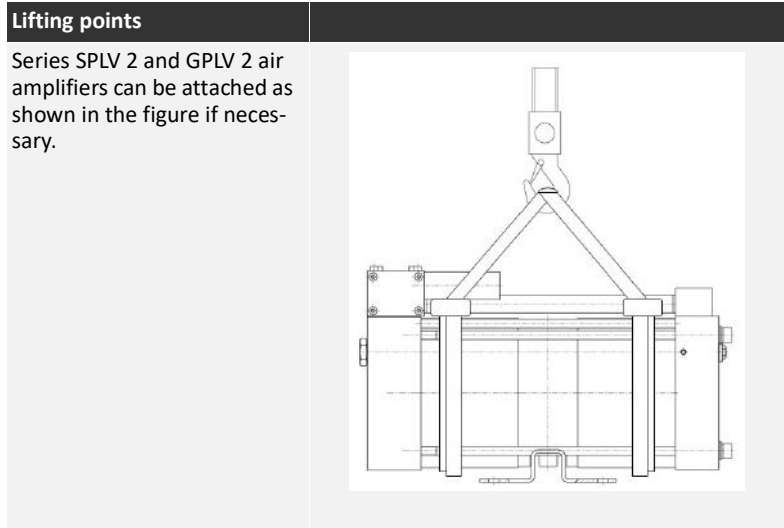

Tab. 5-1 Lifting points of air amplifier

5.3 Installation of connecting lines

The air amplifier is delivered without any connection screw fittings or connecting lines. For this purpose, observe the specifications in section “Connections” and on the general drawing. To prevent malfunctions, the cross-sections of the connecting lines must be designed for the corresponding volume flows.

5.3.1 Connecting the drive air

Connect the connecting line for the drive air to the drive air port (P_L). Observe the connection specifications on the general drawing.

5.3.2 Control air connection

Connect the connecting line for the control air, if applicable, to the control air port (X) of the air amplifier. Observe the connection specifications on the general drawing.

5.3.3 Connecting the inlet line and outlet line

Connect the inlet and outlet lines to the corresponding air amplifier ports (A and B) as appropriate. Observe the connection specifications on the general drawing.

5.3.4 Exhaust silencer installation

If the exhaust air connection pipe of the air amplifier is not installed separately, the enclosed exhaust air silencer must be installed at the corresponding port (E).

5.4 Commissioning

5.4.1 Prerequisites for commissioning

Observe the manual and general drawing of the product. In addition, the following conditions must be met:

- The product must be free of damage.
- The product must be securely attached.
- The connections must be installed correctly.
- Connecting cables/pipes must be free from damage.

5.4.2 Commissioning



WARNING

Risk of injury due to extreme temperatures!

The surfaces of the product can be very hot or very cold. This can lead to accidents resulting in severe injuries or death.

- ▶ Before working on the product, please ensure that the product is at ambient temperature.
-

The following section explains how to commission the air amplifier:

- 1) Check all connections for proper installation.
- 2) Check all connecting lines for mechanical damage.
- 3) Slowly open the shared supply line to drive air inlet P_L and gas inlet A.
 - The operating fluid flows in, and the air amplifier automatically starts pumping.



We recommend increasing the pressure of the supply line slowly, in order to keep the stress on the air amplifier components low during commissioning. This keeps the stroke frequency of the air amplifier low. Otherwise, during the ramp-up phase, until the required operating pressure is reached, operating phases with very high cycle frequencies can occur.

6 Operation

6.1 Prerequisites for operation

Observe the manual and general drawing of the product. In addition, the following conditions must be met:

- The product must be free of damage.
- The product must be securely attached.
- The product is not subject to any vibrations greater than those typically occurring in high-pressure systems.
- A risk assessment has been compiled for the system, and all basic health and safety requirements have been met.

6.2 Normal, safe operation



WARNING

Risk of injury due to extreme temperatures!

The surfaces of the product can be very hot or very cold. This can lead to accidents resulting in severe injuries or death.

- ▶ Before working on the product, please ensure that the product is at ambient temperature.

Normal, safe air amplifier operation must be defined in the context of overall system.

6.3 Abnormal situations during operation

Refer to the general system documentation for measures to consider or implement in case of abnormal operation.

6.4 Signs indicating the product is no longer safe to use

The following signs indicate that the compressor is no longer safe to use. In such cases, the compressor must be put into a safe state immediately.

- Leakage through the piston seal
- Leakage on caps and air cylinders
- Leaking connections
- Visible damage

6.5 Put the air amplifier in a safe state

In a safe state, the air amplifier is depressurised on the drive and high pressure side. The steps necessary in order to achieve a safe state depend on the installation position in the system. Refer to the general system documentation for the required actions.

7 Maintenance

7.1 Maintenance intervals

To ensure safe and smooth operation, the compressor must be checked regularly and serviced, cleaned or repaired as necessary. The individual maintenance activities are described in the following section.

Maximator recommends the intervals listed below. These intervals are calculated based on 1,300,000 strokes/year.

The required maintenance intervals depend on the system and application. The intervals must be adjusted based on the given conditions of use. For dry or very dry operating fluids, the maintenance intervals may have to be reduced.

Activity	before and after each use	daily	weekly	monthly	quarterly	semi-annually	annually	as needed
System inspection			x					
Leak-testing the connections			x					
Check screw fittings and connecting lines for damage			x					
Clean compressor					x			
Check fastening elements and connecting elements					x			
Leak detection						x		
Repair compressor								x

Tab. 7-1 Maintenance intervals

7.2 Maintenance work



WARNING

Risk of injury due to extreme temperatures!

The surfaces of the product can be very hot or very cold. This can lead to accidents resulting in severe injuries or death.

- ▶ Before working on the product, please ensure that the product is at ambient temperature.



WARNING

Risk of injury due to dangerous system status!

Maintenance and inspection activities sometimes require that the air amplifiers be operated with modified connecting lines or without safety equipment. The operation of the air amplifier can lead to accidents with serious or fatal injuries.

- ▶ When performing work, ensure that no hazards are created!



WARNING

Risk of injury due to inappropriate spare parts!

Making repairs using inappropriate spare parts can lead to accidents resulting in severe injuries or death.

- ▶ Only use spare parts that comply with Maximator specifications.



WARNING

Risk of injury when handling lubricants!

Handling lubricants can lead to accidents resulting in severe or fatal injuries.

- ▶ Use protective gloves and goggles.
- ▶ Avoid contact with the skin.
- ▶ Observe the safety data sheet of the lubricant accordingly.

Maintenance

7.2.1 System inspection

The following section explains how to check the air amplifier for proper function:

	Description
Qualifications	Operating the system
Type of maintenance	Check
Interval	weekly
PPE	<ul style="list-style-type: none">– Safety goggles– Hearing protection
1.	Shut off the fluid outlet and adjust p_B to a value that is standard for the system. The air amplifier stops automatically when the final pressure is reached (holding time 60 s).
2.	Vent p_L . p_B does not drop by more than 10% (holding time 30 s).
3.	Set p_L to approx. 50% of the value from the first step and slowly vent P_B . The air amplifier starts up automatically.
4.	If the inspection does not reveal any abnormalities, it is safe to continue using the air amplifier. In case of abnormalities, consult with the maintenance staff.

7.2.2 Leak-testing the connections

The following section explains how to check the connections for leaks:

	Description
Qualifications	Operating the system
Type of maintenance	Check
Interval	weekly
Prerequisites	<ul style="list-style-type: none"> – The air amplifier is easy to access. – All connections are pressurised.
Tools	<ul style="list-style-type: none"> – Torch – Cleaning cloth – Leak detection spray
PPE	Safety goggles
1.	Check connections for leaks. Use leak detection spray.
2.	If the inspection does not reveal any abnormalities, it is safe to continue using the air amplifier. In case of abnormalities, consult with the maintenance staff.

7.2.3 Inspect screws and connecting lines

The following section explains how to inspect the screw fittings and connecting lines:

	Description
Qualifications	Operating the system
Type of maintenance	Check
Interval	weekly
Prerequisites	The air amplifier is easy to access.
Tools	<ul style="list-style-type: none"> – Torch – Cleaning cloth
1.	Visual inspection of the screw fittings and connecting lines. Is there any visible damage or other visible signs of wear?
2.	If the inspection does not reveal any abnormalities, it is safe to continue using the air amplifier. In case of abnormalities, consult with the maintenance staff.

Maintenance

7.2.4 Clean air amplifier

The following section explains how to clean the air amplifier:

	Description
Qualifications	Clean air amplifier
Type of maintenance	Cleaning
Interval	quarterly
Prerequisites	<ul style="list-style-type: none">– The air amplifier is easy to access.– The air amplifier is depressurised.
Tools	<ul style="list-style-type: none">– Cotton cleaning cloth– Solvent-free cleaning product
1.	Clean air amplifier.
2.	The cleaning process has been successful if: <ul style="list-style-type: none">– The air amplifier is free of dirt.– ports and silencers are free of dirt.

7.2.5 Check fastening elements and connecting elements

The following section explains how to inspect the screw fittings on the air amplifier and the connection ports:

	Description
Qualifications	Repair and service the air amplifier
Type of maintenance	Check
Interval	quarterly
Prerequisites	<ul style="list-style-type: none">– The air amplifier is easy to access.– The air amplifier is depressurised.
Tools	Torque spanner
1.	Check all fasteners and retighten if necessary.
2.	Check all connection ports and retighten if necessary.
3.	The inspection has been successful if: <ul style="list-style-type: none">– all fasteners are properly tightened.– all connection ports are properly tightened.

7.2.6 Leak detection

The following section explains how to check the aforementioned air amplifiers for leakage:

	Description
Qualifications	Repair and service the air amplifier
Type of maintenance	Check
Interval	semi-annually
Prerequisites	The air amplifier is easy to access.
Tools	<ul style="list-style-type: none"> – Torch – Cleaning cloth – Leak detection spray
PPE	<ul style="list-style-type: none"> – Safety goggles – Hearing protection
1.	Check all connections for leaks. Use leak detection spray on the drive unit.
2.	Shut off gas outlet (B)
3.	Approach stall pressure
4.	Determine how many strokes the air amplifier performs at stall pressure n_{sp} (holding time 60 s).
5.	Vent p_L p_B does not drop by more than 10% (holding time 30 s).
6.	Set p_L to approx. 50% of the value from the first step and slowly vent P_B . The air amplifier will start up automatically.
7.	<ul style="list-style-type: none"> – Vent p_L – Vent p_B – Disassemble spool valve – Inspect spool valve – Are the seals worn out? – Is there still enough lubricant?
8.	<p>The inspection has been successful if:</p> <ul style="list-style-type: none"> – all measurements are satisfactory. – the spool valve is OK. <p>If the air amplifier does not pass the inspection, it must be repaired or replaced.</p>

Maintenance

7.2.7 Repair air amplifier

The following section explains how to repair the compressor:

	Description
Qualifications	Repair and service the compressor
Type of maintenance	Repair
Interval	as needed
Prerequisites	Clean, even work area with ample lighting
Tools	<ul style="list-style-type: none">– Cleaning rags– Cleaning product– Torch– Lubricant as per drawing
PPE	<ul style="list-style-type: none">– Safety goggles– Protective gloves
1.	Disassemble the compressor.
2.	Clean the inside and outside of the compressor.
3.	Replace all seals and guide elements.
4.	Replace damaged compressor components as necessary.
5.	Assemble compressor. Apply a thin and even layer of lubricant to the following surfaces: <ul style="list-style-type: none">– Contact surfaces of seals and guide elements– Seals Specially designated areas must be treated according to drawing indications.
6.	Check compressor. This includes the following maintenance work: <ul style="list-style-type: none">– 7.2.1 - System check– 7.2.6 - Leak test
7.	If the compressor has passed all tests, the repair is complete.



Maximator devices can be sent in for repairs to your local Maximator representative. All the necessary details are available on the Maximator website <http://www.maximator.de>

7.3 Spare parts and consumables



WARNING

Risk of injury due to inappropriate spare parts!

Making repairs using inappropriate spare parts can lead to accidents resulting in severe injuries or death.

- ▶ Only use spare parts that comply with Maximator specifications.

A list of the available spare parts, spare part kits and consumables can be found on the general drawing.

7.4 Accessories and special tools

A variety of special accessories are available for the air amplifier. Please consult with our sales department.

The tools used for the products are continuously being updated and supplemented.

An overview of the currently available tools is accessible upon request when contacting the Maximator customer service.

7.5 Customer service

Our customer service is also at your disposal for technical details and repairs:

Address	Maximator GmbH Ullrichstraße 1-2 99734 Nordhausen Germany
Customer service phone Mon. – Thurs.: 06:30 – 16:15 CET Fri.: 06:30 – 14:00 CET	+49 3631 9533-5444
Fax	+49 3631 9533-5065
Email	service@maximator.de
Website	www.maximator.de/service

Feedback and experiences resulting from the application of our products and potentially leading to an optimisation of such are appreciated.

8 Troubleshooting

The following is a list of typical product faults, their causes and the appropriate solutions.

If you experience any other specific or unexpected faults, please notify us at service@maximator.de

8.1 Drive side

Fault	Cause of fault	Solution
The compressor does not operate at low air pressure	Friction of the O-rings on the spool valve is too high	<ul style="list-style-type: none"> – Relubricate – Replace the O-rings on the spool valve
The compressor does not operate at low air pressure	O-rings will swell if the wrong oil or lubricant is used	<ul style="list-style-type: none"> – Replace the O-rings – Use lubricant specified in drawing
The compressor does not work	The control air is not connected	Control air connection
The compressor does not work or works slowly.	The control air is not adequately pressurised	The control air must be at minimum p_L
The compressor does not work or works slowly.	Ice has formed on the silencer or spool valve	Dehumidify the compressed air
The compressor does not work or works slowly.	Formation of residue in the silencer	Clean the silencer; replace if necessary
The compressor does not work; air escapes through the silencer	The O-rings on the spool valve are faulty	Replace and lubricate the O-rings
The compressor does not work; air escapes through the silencer	The O-ring on the air piston is faulty or worn	Replace and lubricate the O-ring
The compressor does not work; air flows through air supply port "V1"	The spool valve is jammed.	<ul style="list-style-type: none"> – Clean the spool valve and sleeve – Check the O-rings and sleeves, and replace them if necessary – Lubricate
The compressor operates with high frequency and short strokes	The pilot valve in the top or bottom cap is faulty	Clean, lubricate and, if necessary, replace the pilot valve

Tab. 8-1 Trouble shooting on the drive side

8.2 High pressure side

Fault	Cause of fault	Solution
The compressor operates without delivering the gas, or it operates erratically. It does not reach the calculated operating pressure.	Check valve failure	Inspect the check valves and replace if necessary
Operating fluid escapes through the silencer or other designated leak points	The O-ring/seal ring on the air piston is faulty or worn	Replace and lubricate the O-ring/seal ring

Tab. 8-2 Troubleshooting

9 Removal and disposal

9.1 Prerequisites for removal and disposal

Follow the manual and general drawing for the product.
In addition, the following conditions must be met:

- The product must be in a safe state.
- The product must be at ambient temperature.

9.2 Removal



WARNING

Risk of injury when handling lubricants!

Handling lubricants can lead to accidents resulting in severe or fatal injuries.

- ▶ Use protective gloves and goggles.
 - ▶ Avoid contact with the skin.
 - ▶ Observe the safety data sheet of the lubricant accordingly.
-

To remove the air amplifier, proceed as follows:

- Shut down the air amplifier.
- Depressurise it.
- Disconnect the connections and remove fastening screws.
- Disassemble the air amplifier.

9.3 Disposal



WARNING

Risk of injury when handling lubricants!

Handling lubricants can lead to accidents resulting in severe or fatal injuries.

- ▶ Use protective gloves and goggles.
 - ▶ Avoid contact with the skin.
 - ▶ Observe the safety data sheet of the lubricant accordingly.
-

If the service life has expired: Send the product back to Maximator, postage paid, for proper disposal.

10 Use in explosion-prone zones

10.1 General information



If the compressors feature an ATEX label and a Declaration of Conformity to 2014/34/EU was provided, it will be intended for the use in areas conforming to the applicable device label. The designation is indicated on the rating plate and on the general drawing.

The individual parts of the label are explained in the example below.

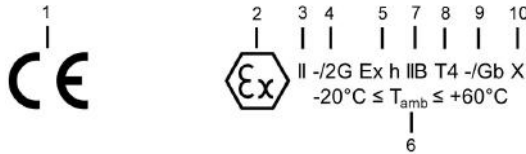

Fig. 10-1 Exemplary figure - ATEX label

- 1 CE symbol
- 2 Ex-symbol
- 3 Equipment group II: The air amplifier may be used in potentially explosive atmospheres, except in mining.
- 4 Equipment category -/2G: The device boasts multiple equipment categories. Admissible zones can be found in figure 10-2 "Display of ATEX zones".
- 5 Ex h marking: Designated for use as per DIN EN ISO 80079-36/37.
- 6 Designation of ambient temperature: Permissible range of ambient temperature.
- 7 Explosion group: The device is designated for use in potentially explosive gas atmospheres, with gases from Group IIB.
- 8 Temperature class: Under compliance with the indications in the operating manual, the device can be used in the temperature class indicated.
- 9 Equipment protection level (EPL) -/Gb: The device boasts multiple equipment protection levels. Admissible zones can be found in figure 10-2 "Display of ATEX zones".
- 10 Additional marking X: Further details with regard to explosion protection that go beyond the content about the ATEX label can be found in the operating instructions.

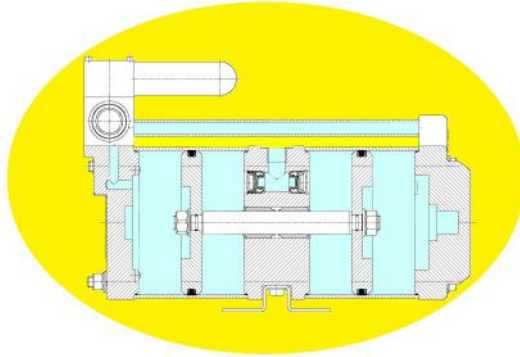

Fig. 10-2 Display of ATEX zones

Legend:

No zone:



Zone 0:



Zone 1:



Zone 2:



10.2

Temperature class

The temperature of the compressor mainly depends on the temperature of the operating fluid. Refer to the following table for the maximum operating fluid temperature required in order to attain temperature class T4:

Max. temperature of operating fluid	Temperature class
60°C	T4

Tab. 10-1 Temperature classes

The adiabatic compression is already included in the temperature class. It therefore no longer needs to be considered separately.

The compressor should not be insulated. If it is nonetheless insulated, the equipment manufacturer must determine the temperature class of the equipment accordingly.

10.3 **Operation and maintenance**

Static electricity on the product can lead to explosions. This may result in severe or fatal injuries.

Never use high-power mechanisms for charge generation on or near the product.

The possibility of an explosive atmosphere must be excluded before undertaking any and all work on the product – maintenance, cleaning or any other activity.

In order to ensure adequate safety during regular operation, the function of the air amplifier and compliance with the thresholds specified in these instructions must be monitored accordingly.

In doing so, the maintenance activities must be carried out at intervals that are appropriate for the application.

For safe operation, the devices may no longer be used after the leakage thresholds have been exceeded.

Summary of ignition hazards

11 Summary of ignition hazards

Ignition hazard Source of ignition	Cause	Protective measure implemented
Hot surfaces	Heating by the operating fluid and compression	<ul style="list-style-type: none"> – Temperature class definition – Insulation prohibited
Hot surfaces	Friction	<ul style="list-style-type: none"> – Operating fluid quality specification – Specification of maintenance activities and intervals
Mechanically generated sparks	Ignition due to external impact on the device	Impact resistance tests performed
Mechanically generated sparks	Ingression of foreign particles	Required IP protection rating ensured
Mechanically generated sparks	Ignition of dust in the equipment	Specification of maintenance activities and intervals
Mechanically generated sparks	Metallic friction due to wear	Specification of maintenance activities and intervals
Mechanically generated sparks	Impact sparks – housing or internal components	<ul style="list-style-type: none"> – Appropriate housing materials – Ignition protection type c “constructional safety” – Design in accordance with impact energy specifications
Flames and hot gases	Ignition of lubricants and operating fluids	<ul style="list-style-type: none"> – Appropriate selection of lubricants – Temperature class definition – Ignition protection type c “constructional safety”
Static electricity	Charging of insulated components	All parts are conductively interconnected
Static electricity	Charging of non-conductive device parts or layers	Design in accordance with layer thickness specifications
Static electricity	Charging due to high-power mechanisms	Exclusion of powerful charge generating mechanisms
Chemical reaction	Reaction of the operating fluids and parts of the device	Adequate selection of materials

Tab. 11-1 Summary of the applicable ignition hazards identified and the protective measures implemented

Appendix

The appendix comprises the following documents:

- EU Declaration of Conformity air amplifier MPLV2/SPLV2/GPLV2
- Declaration of Incorporation air amplifier MPLV2/SPLV2/GPLV2
- Description of the basic safety and occupational health and safety requirements

MAXIMATOR® **Maximum Pressure.**

EU-Konformitätserklärung

Hiermit erklären wir, dass die Bauart von pneumatisch angetriebenen Druckluftnachverdichtern der Baureihen:
MPLV2, SPLV2, GPLV2
mit einer Seriennummer von **23000001** und höher
in der gelieferten Ausführung folgenden einschlägige Harmonisierungsrechtsvorschriften der Union erfüllt:

EU-Richtlinie Explosionsschutz 2014/34/EU

Angewendete harmonisierte Normen und technische Spezifikationen:
DIN EN ISO 12100:2011-03
DIN EN ISO 80079-36:2016-12
DIN EN ISO 80079-37:2016-12

Notifizierte Stelle eingeschaltet zur Aufbewahrung der Unterlagen nach 2014/34/EU:
0102 PTB - Braunschweig, (Bundesallee 100, 38116 Braunschweig)

Weitere einschlägige Bestimmungen: EG Maschinenrichtlinie (2006/42/EG) (Unvollständige Maschine)

Anschrift Hersteller: **MAXIMATOR GmbH, Lange Straße 6, 99734 Nordhausen / Deutschland**
Die alleinige Verantwortung für die Ausstellung dieser Konformitätserklärung trägt der Hersteller.

(Original)

EU Declaration of Conformity

Herewith, we declare that the model of pneumatic driven air amplifier type:
MPLV2, SPLV2, GPLV2
with a serialized ID of **20000001** and above
as supplied are in conformity with the relevant Union harmonisation regulations:

EU Explosion Protection Directive 2014/34/EU

Harmonised standards and technical specifications applied:
DIN EN ISO 12100:2011-03
DIN EN ISO 80079-36:2016-12
DIN EN ISO 80079-37:2016-12

Notified body involved for preserving the documents in compliance with 2014/34/EU:
0102 PTB - Braunschweig (Bundesallee 100, 38116 Braunschweig)

Further likewise applicable directives: Machinery directive (2006/42/EC) (partly completed machinery)

Name and address of manufacturer: **MAXIMATOR GmbH, Lange Straße 6, 99734 Nordhausen / Germany**
This declaration of conformity is issued under the sole responsibility of the manufacturer.

(Translation)

Nordhausen, den **25.05.2023** (Nordhausen, 25.05.2023)

.....
Stefan Roloff (Divisionsleitung Components) (Division Manager Components)

MAXIMATOR®

Maximum Pressure.

Einbauerklärung nach 2006/42/EG, Anhang II, Nr.1 B

Inhalt gemäß 2006/42/EG, Anhang II, Nr.1 B.

Anschrift Hersteller: MAXIMATOR GmbH
Lange Straße 6
99734 Nordhausen / Deutschland

Der Dokumentationsbeauftragte ist bevollmächtigt, die speziellen technischen Unterlagen nach Anhang VII B zusammenzustellen: dokumentationsbeauftragter@maximator.de / Tel.: 03631-9533-5109

Die Bauart von pneumatisch angetriebenen Druckluftnachverdichtern der Baureihe:

MPLV2, SPLV2, GPLV2

mit einer Seriennummer von **23000001** und höher

ist eine unvollständige Maschine nach Artikel 2g und ausschließlich zum Einbau in oder zum Zusammenbau mit einer anderen Maschine oder Ausrüstung vorgesehen.

Grundlegende Sicherheits- und Gesundheitsschutzanforderung gemäß Anhang I dieser Richtlinie kommen zur Anwendung und wurden eingehalten :

Auflistung siehe separate Anlage

Die speziellen technischen Unterlagen gemäß Anhang VII B wurden erstellt und sie werden der zuständigen nationalen Behörde auf Verlangen in elektronischer Form übermittelt.

Diese unvollständige Maschine darf erst dann in Betrieb genommen werden, wenn festgestellt wurde, dass die Maschine, in welche die unvollständige Maschine eingebaut werden soll, den Bestimmungen der Maschinenrichtlinie entspricht.

Declaration of Incorporation acc. to 2006/42/EC, Annex II, Nr.1 B

Contents acc. to 2006/42/EC, Annex II, Nr.1 B.

Name and address of manufacturer: MAXIMATOR GmbH
Lange Straße 6
99734 Nordhausen / Germany

The documentation officer is authorised to compile the relevant technical documentation as set forth in Annex VII B. dokumentationsbeauftragter@maximator.de / Tel.: +49(0)3631-9533-5109

The model of pneumatic driven air amplifier type:

MPLV2, SPLV2, GPLV2

with a serialized ID of **23000001** and above

is a partly completed machinery as defined in Article 2g and exclusively envisaged for installation into or assembly with other machinery or equipment.

Essential health and safety requirements (EHSR) acc. to Annex I to this directive have been applied and complied with:

See separate Appendix

The relevant technical documentation according to Annex VII B was compiled and will be forwarded to the competent national authority in electronic format upon request.

The partly completed machinery must not be put into service until the final machinery into which it is to be incorporated has been declared in conformity with the provisions of the Directive on Machinery.

Nordhausen, den 25.05.2023 (Nordhausen, 25.05.2023)

.....
Steffen Roloff (Divisionsleitung Components) (Division Manager Components)

Appendix

Description of the basic safety and occupational health and safety requirements (MRL 2006/42/EC, Appendix I)

No.	Basic requirement	Applicable	Met	Comment
1.	BASIC SAFETY AND OCCUPATIONAL HEALTH AND SAFETY REQUIREMENTS			
1.1	GENERAL INFORMATION			
1.1.1	Terminology	Yes	Yes	
1.1.2	Safety integration principles	Yes	Yes	
1.1.3	Materials and products	Yes	Yes	
1.1.4	Lighting	No		
1.1.5	Machine design regarding handling	Yes	Yes	Device corresponds to the design common for the market
1.1.6	Ergonomics	No		
1.1.7	Operator's console	No		
1.1.8	Seats	No		
1.2	CONTROLS AND CONTROL DEVICES			
1.2.1	Control safety and reliability	Yes	No	Unintended start-up, changing the parameters
1.2.2	Actuators	No		
1.2.3	Starting the system	Yes	No	Unintended start-up, changing the operating state
1.2.4	Shut-down			
1.2.4.1	Normal shut-down	Yes	No	No control device for shut-down
1.2.4.2	Operational shut-down	No		
1.2.4.3	Emergency shut-down	Yes	No	No emergency stop
1.2.4.4	Completeness of machines	No		
1.2.5	Selection of control or operating modes	No		
1.2.6	Fault in the energy supply	Yes	No	Unintended start-up
1.3	PROTECTIVE MEASURES AGAINST MECHANICAL HAZARDS			
1.3.1	Risk of stability loss	Yes	Yes	Design is non-critical

No.	Basic requirement	Applicable	Met	Comment
1.3.2	Risk of breakage during operation	Yes	Yes	
1.3.3	Risks posed by dropping or ejected objects	No		
1.3.4	Risks posed by surfaces, edges and corners	Yes	Yes	Deburring generally required
1.3.5	Risks posed by multiple machines combined	No		
1.3.6	Risks posed by changed usage conditions	Yes	No	
1.3.7	Risks posed by movable parts	Yes	Yes	No moving parts that can be accessed from the outside
1.3.8	Selection of protective equipment against risks posed by movable parts	No		
1.3.8.1	Moving parts of the power transmission	No		
1.3.8.2	Moving parts that are involved in the work process	No		
1.3.9	Risk of uncontrolled movements	No		
1.4	PROTECTIVE EQUIPMENT REQUIREMENTS			
1.4.1	General requirements	No		
1.4.2	Special specifications for guards			
1.4.2.1	Fixed guards	No		
1.4.2.2	Movable guards with guard locking	No		
1.4.2.3	Access-restricting adjustable guards	No		
1.4.3	Special specifications for protective devices	No		
1.5	RISKS POSED BY OTHER HAZARDS			
1.5.1	Electrical energy supply	No		
1.5.2	Static electricity	Yes	Yes	See ATEX
1.5.3	Non-electrical energy supply	Yes	No	Ice formation, flying ice, raised particles, suffocation, noise

Appendix

No.	Basic requirement	Applicable	Met	Comment
1.5.4	Assembly fault	Yes	Yes	Connection labels
1.5.5	Extreme temperatures	Yes	No	Machine may heat up or cool down
1.5.6	Fire	Yes	No	
1.5.7	Explosion	Yes		Considered separately
1.5.8	Noise	Yes	No	Depending on installation and application
1.5.9	Vibrations	Yes	Yes	Vibrations within the range common for the market
01/05/2010	Radiation	No		
01/05/2011	Radiation from the outside	No		
01/05/2012	Laser radiation	No		
01/05/2013	Emission of hazardous materials and substances	Yes	No	Exposition and leakage of operating fluids
01/05/2014	Risk of being locked into the machine	No		
01/05/2015	Risk of slipping, tripping or falling	No		
01/05/2016	Lightning strike	No		
1.6	MAINTENANCE			
1.6.1	Machine maintenance	Yes	No	In context of the overall system
1.6.2	Access to the operator stations and access points for maintenance	Yes	Yes	Design common for the market
1.6.3	Disconnection of energy sources	Yes	No	Unavailable
1.6.4	Operating personnel interventions	Yes	Yes	Design common for the market

No.	Basic requirement	Applicable	Met	Comment
1.6.5	Cleaning of machine parts in the interior	Yes	Yes	The capacity of the internal volume in question is not sufficient to pose a risk to the maintenance personnel due to residues of the permissible operating fluids when the compressor is at a standstill.
1.7	INFORMATION			
1.7.1	Information and warnings on the machine	No		
1.7.1.1	Information and information equipment	No		
1.7.1.2	Warning equipment	No		
1.7.2	Warning of residual risks	Yes	No	In context of the overall system
1.7.3	Machine labels	Yes	Yes	
1.7.4	Operating manual	Yes	Yes	Installation manual
1.7.4.1	General principles for drafting the operating instructions	Yes	Yes	
1.7.4.2	Operating manual contents	Yes	Yes	
1.7.4.3	Sales brochures	Yes	Yes	
2-6	Not applicable			

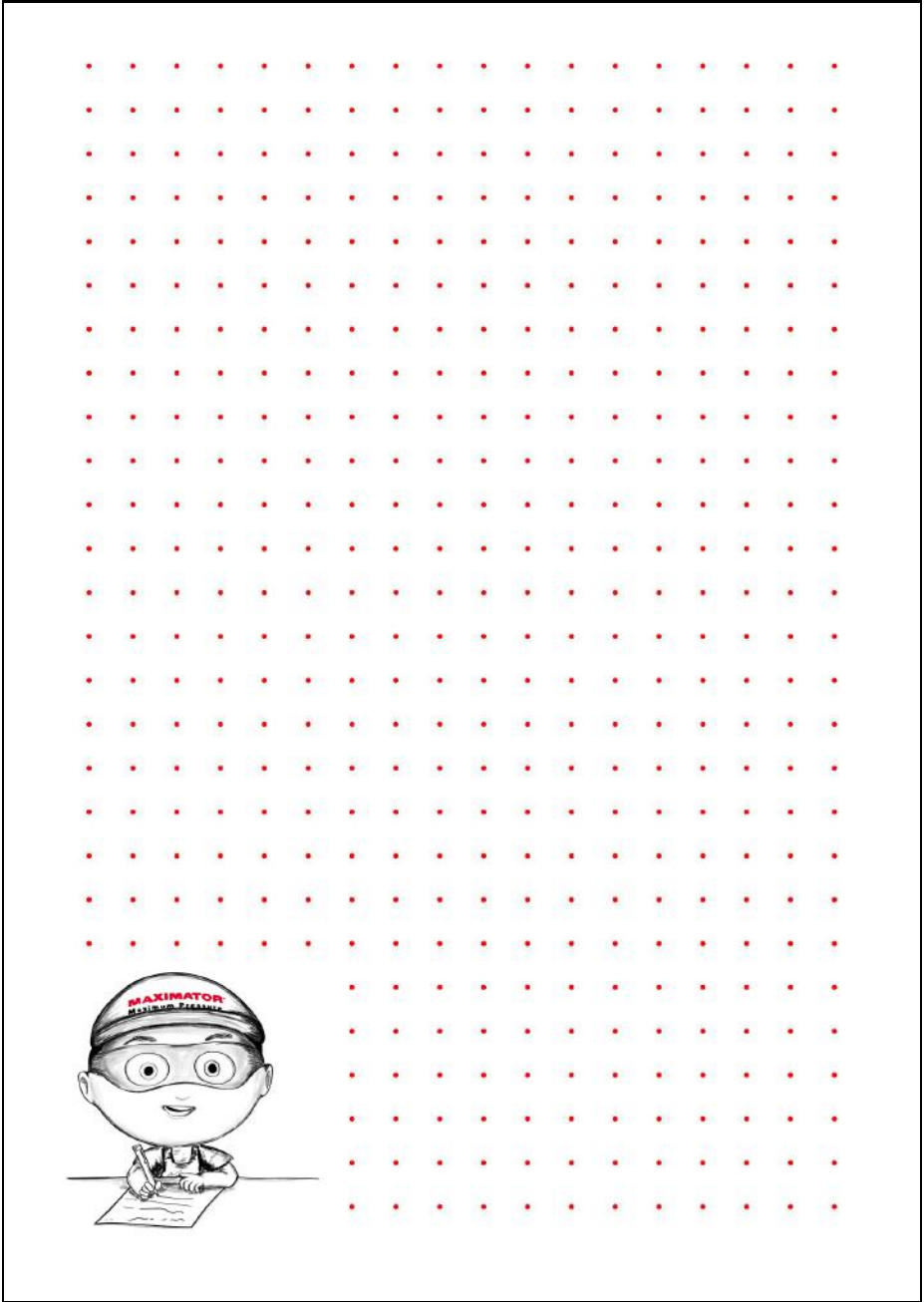

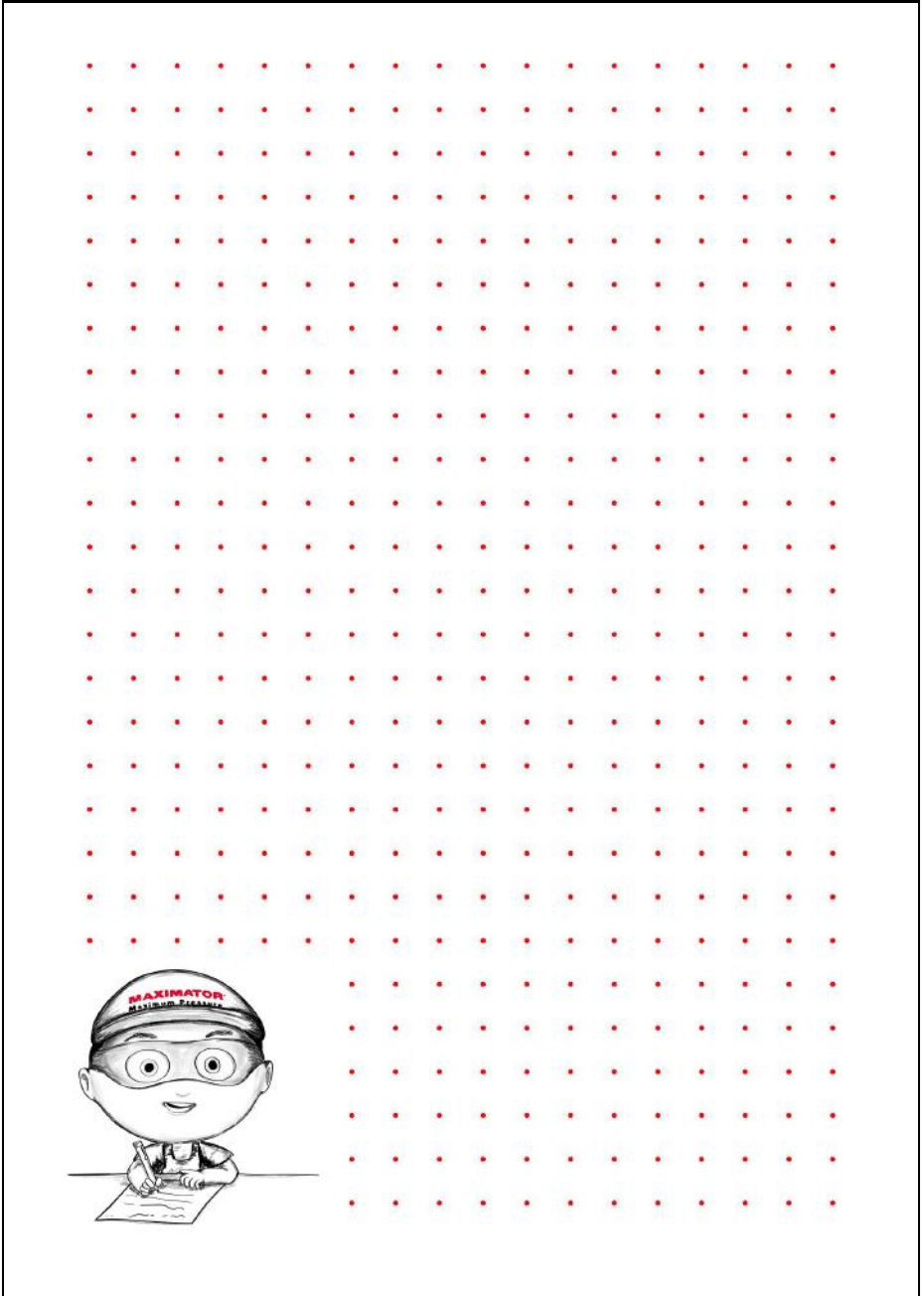

Appendix

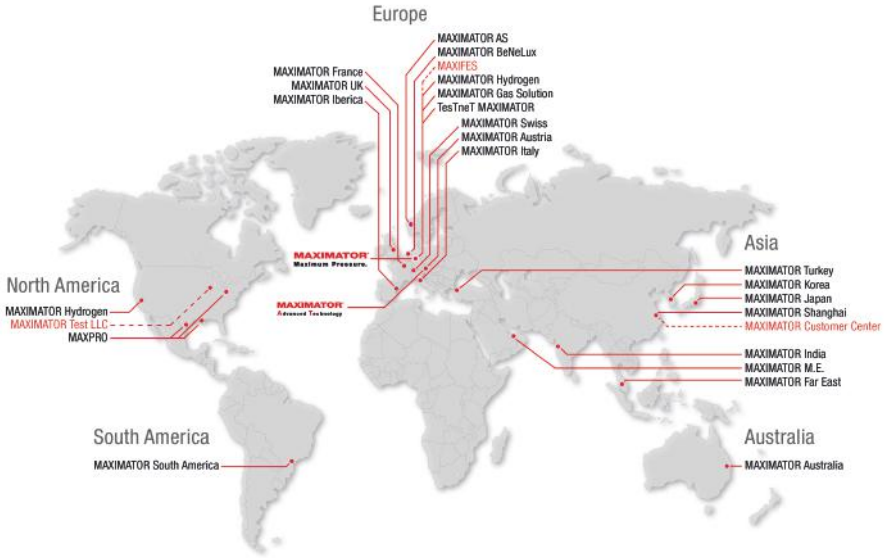

Visit our website at: www.maximator.de

1999.0051 EN